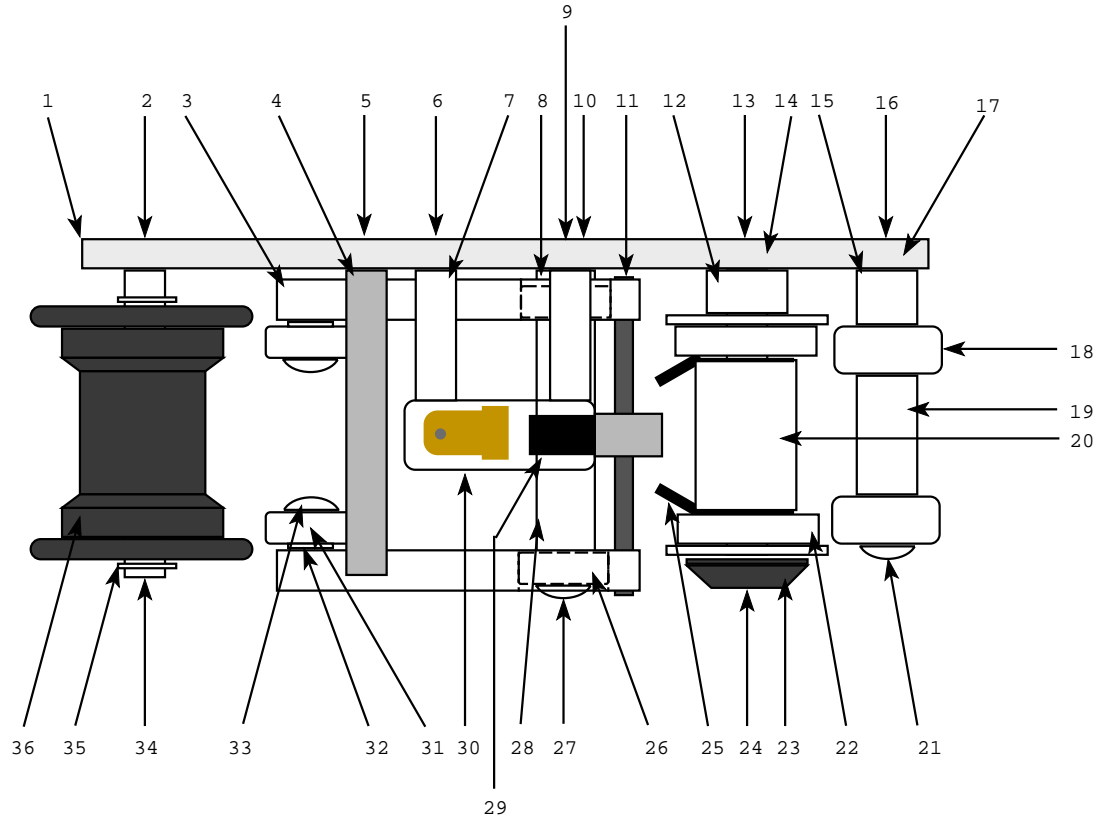

**UDH-100/132 Standard Cue Detector/Failsafe Parts List (Ball Bearing type Ground Roller)**

Ref.#	Part #	Description	Ref.#	Part #	Description
1	UDH-1-101	Main Chassis	19	UDH-1-106-4	Spacer, Ground Roller
2	SP8F-1/2	8-32x1/2" Phillips Flat Head Screw	20	PCD-751	Spacer, Cue Roller
3	UDH-1-102	Failsafe Arm	21	SP8P-3/8	8-32x3/8" Phillips Pan Head Screw
4	UDH-1-109	Failsafe Arm Upper Stop	22	SFR6ZZ	Bearing, Cue Roller
5	SP8 F-1/2	8-32x1/2" Phillips Flat Head Screw	23	PCD-754	Cap, Cue Roller End
6	SP4F-1/2	4-40x 1/2" Phillips Flat Head Screw	24	SHCS8-3/8	8-32x3/8" Socket Head Cap Screw
7	UDH-1-108	Standoff Failsafe Switch (2)	25	PV18-38R	Lug
8	UDH-1-106-1	Spacer, Failsafe Arm Inner	26	R4ZZ	Bearing
9	SP8F-1/2	8-32x1/2" Phillips Flat Head Screw	27	SP8P-3/8	8-32x3/8" Phillips Pan Head Screw
10	UDH-1-105	Shaft, Failsafe Arm Mounting	28	UDH-1-106-2	Spacer, Failsafe Arm Center (2)
11	DP.0625x375	Dowel Pin 1/16x3/8	29	UDH-1-111	Failsafe Arm Lower Stop
12	UDH-1-104	Insulating Spacer	30	V3L-2102-D8	Switch, Failsafe
13	SP8F-1/2	8-32x1/2" Phillips Flat Head Screw	31	R4ZZ	Bearing
14	UDH-1-1205	Shaft, Cue Bearing	32	UDH-4-97	Spacer, Failsafe Arm Bearing
15	UDH-1-106-3	Spacer, Ground Roller Inner	33	SP10P-1/2	10-32x1/2" Phillips Pan Head Screw
16	SP8F-1/2	8-32x1/2" Phillips Flat Head Screw	34	UDH-1-119	Shaft, Exit Roller
17	UDH-1-107	Shaft, Ground Roller	35	SR-25	Ring, 1/4" Retaining
18	R4AZZ	Bearing, Ground Roller	36	720336	Roller, Film By-pass (w/Bearings)